



**12 VOLT DC POWER
ASSISTED STEERING
INSTALLATION
INSTRUCTIONS
&
OWNER'S MANUAL**

(05/03/03)

MANUFACTURED BY

HY-DRIVE ENGINEERING PTY LTD

ACN 007 660 808

59 WINGFIELD ROAD, WINGFIELD,
SOUTH AUSTRALIA 5013
TELEPHONE (08) 82431633, FAX: (08) 84457938

INDEX

Points to Watch Prior To Installation	4-5
Pump Set Installation Instructions	6-6
Electrical Installation Instructions	7-7
Steering Helm Instructions	8-9
Steering Column Instructions	9-9
Installation on Outboard Motors	10-10
Tilt Tube Cylinders.....	10-11
Bull Horn Cylinders	12-14
Installation on Stern Drives	15-15
Installation on Standard Rudders	15-15
Single Cylinder Installations	16-17
Hoses	17-17
Bleeding.....	18-18
Single Helm to Outboard Cylinder Circuit.....	19-19
Single Helm to Inboard Cylinder Circuit	20-20
Fluid Link For Catamaran Circuits.....	21-21
Dual Helm to Outboard Circuits.....	22-22
Dual Helm with Autopilot Circuits	23-23
Servicing Information.....	24-24
Maintenance	24-25

SAFETY INFORMATION

THIS MANUAL HAS BEEN SUPPLIED FOR *YOUR* BENEFIT AND PROTECTION. IT IS OF **NO** VALUE IF YOU DO NOT READ IT **CAREFULLY** PRIOR TO ATTEMPTING TO INSTALL YOUR NEW HYDRIVE UNIT. FAILURE TO ADHERE TO THESE INSTRUCTIONS MAY RESULT IN **STEERING FAILURE AND POTENTIAL DAMAGE TO THE BOAT AND INJURY TO THE OCCUPANTS. DO NOT TAKE SHORT-CUTS.** Stick **strictly** with our methods and do not adopt your own. It will make the system faster to install and safer to use.

PLEASE READ THIS SECTION MOST CAREFULLY

It is absolutely *ESSENTIAL* that you read **ALL** the information contained in this **MANUAL** relating to your particular model and installation type **BEFORE** you attempt to install the unit. **FAILURE** to do so may result in problems when you come to bleed the unit later.

ATTENTION HYDRAULIC EXPERTS. It is essential that you read **this manual BEFORE attempting to install the system.** We have a much higher incidence of installer-error with people who claim hydraulic expertise, than with your average handyman because they proceed on the mistaken assumption that Hydrive systems are just like all the others, or that they know all there is to know about installing our equipment. The short time taken to read this booklet will ensure that the installation goes without a hitch.

VERY IMPORTANT POINTS TO NOTE

Before proceeding please read the following sections relating to items that are of major importance to the correct installation and selection of components.

DO NOT USE BRAKE FLUID! IN THIS SYSTEM - IT WILL DAMAGE SEALS AND OTHER COMPONENTS.

ALL WARRANTY IS VOID IF INCORRECT TUBING IS USED.

IMPORTANT NOTES RE OUTBOARD MOTORS: All outboard motors are equipped with small "*TRIM*" tabs immediately behind the propeller. In some motors, these also act as Anodes. ***DO NOT UNDERESTIMATE THE IMPORTANCE OF THESE SMALL ITEMS.***

These must be adjusted once the motors are installed on the boat, and should be done for the normal cruising speed of the vessel. For high horsepower/performance motors, these are of critical importance as incorrect positions can **INCREASE** steering torques as much as 500%. They are **NOT** factory set and **MUST** be done after proper installation. Experimentation is the only means of arriving at the best results.

Where they are also used as anodes, they should be maintained in good condition and replaced as soon as corrosion begins to affect steering performance. It is also important that you appreciate the effect of poor motor trim angle to the transom, which can also increase steering effort unnecessarily. **No steering gear can compensate for poor trim.**

POINTS TO WATCH

PRIOR TO INSTALLATION

All hydraulic equipment requires a good degree of workmanship for its installation, and this is also true of steering gear, if future performance and serviceability is to be assured. Extra care must be taken by the installer to see the following points are closely watched.

BE CLEAN when installing the unit. Strain all oil - even if it is new (unless out of new PLASTIC containers). It only takes a few moments to be particular.

Ensure that all pipe joints and fittings are tight and carefully sealed using **LOC-TITE THREAD SEALANT** or similar product. **Avoid the use of Teflon Tape as it can be introduced into the system by inexperienced installers. THIS MAY CAUSE VALVE FAILURE.**

Use the **RIGHT TOOLS** for the job. **DO NOT USE** stilsen wrenches, pliers or incorrect spanners that will burr the fittings etc. Don't over-tighten bleeder valves etc.

NOTE:

Dirt, air and loose fittings are the common enemies of any hydraulic system. Loctite thread sealant must be used on all "Pipe threads", and remember, fittings may be tight enough not to leak oil.....but loose enough to suck air into the system.

After installation, **grease all points** that have grease nipples. (Not bleeder nipples, nor is that applicable to 210BH, 212BH, 210T & 210TSE cylinders.) Use good quality waterproof grease. This should be carried out every 6 months at which time you should always check the security of all bolts, nuts and split pins on the steering mechanism (Not every model has such items, so check your system thoroughly and become familiar with it). Vibration can often result in nuts becoming loose.

INSTALLATION INSTRUCTIONS

PUMP SET

1. Locate pump set as close as practical to the steering helm unit.
2. Mount pump set in accessible, dry ventilated space.
3. Install pump set with filler cap on the top.
4. Install fitting: M16 x 1.5 “O” ring (Without flat washer)
5. Automatic Transmission fluid is the only fluid to be used. (i.e. Dexron II or Dexron III)

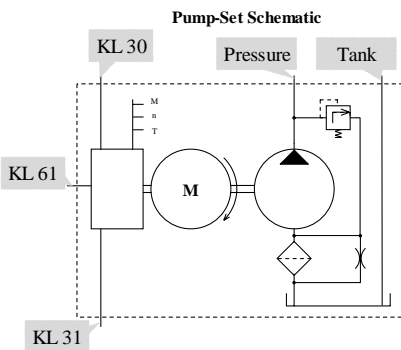
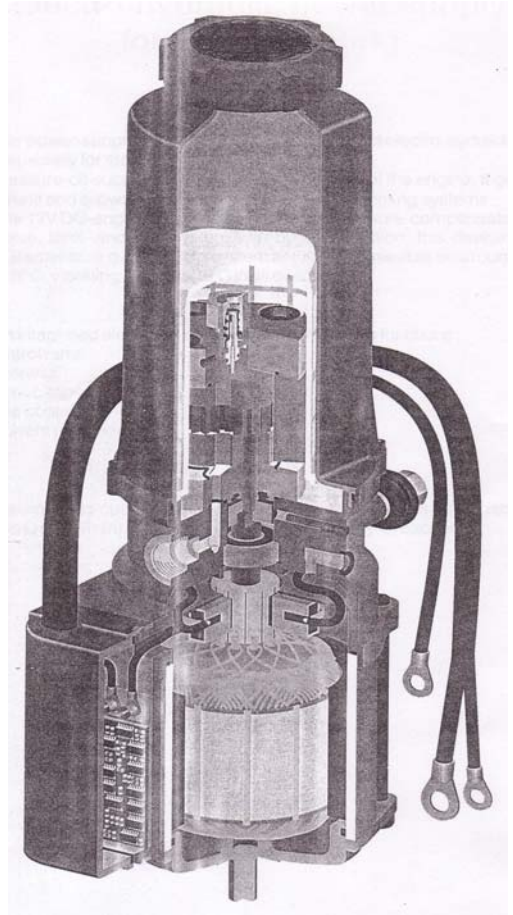

ELECTRICAL

1. Locate fuse block close to 12-volt DC battery supply.
2. Install 70-amp fuse. (Not included in kit, we recommend you carry spares.)
3. Run wires as per the drawing below.
4. **Colour code:**

Black wire	=	Positive current
Brown wire	=	Negative current
Blue wire	=	Pump set electric motor

“ON / OFF”
5. Pump set has a separate “ON / OFF” circuit. (Blue wire) This circuit may be energized through a separate “Toggle” switch on the engine ignition switch.

WARNING: Positive (Black) and Negative (Brown) live power must be connected before activating electric current through the toggle “ON / OFF” switch circuit. Failure to have the correct current connected to black and brown wires before activating the blue starter wire will “BLOW” the electronic junction box on the pump set.

FULL POWER STEERING ELECTRICAL CONNECTIONS

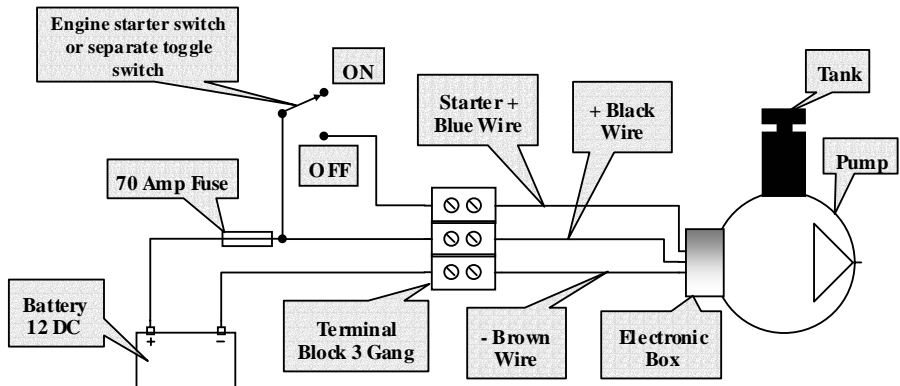

STEERING HELM

1. Use drill template supplied at the back of this book, for helm column cut out.
2. Steering helm and steering column are mounted from behind the dash.
3. Install elbows using the loctite provided on all “pipe” threads. Position direction of the elbows to suit your hose line runs. Wait 30 minutes for loctite to cure and go hard.

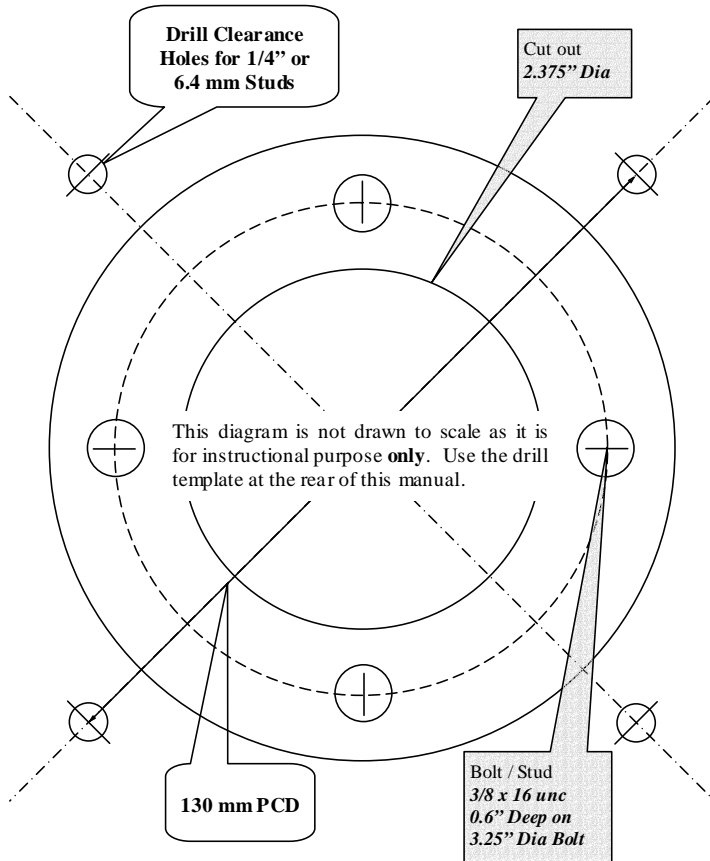

Power Steering Helms

All Models—PS50, PS80, PS100, PS125, PS160, PS200, PS250,
PS315, PS400, PS500



PS50 Helm Unit

(Shown with optional Dash Cowl)

1. Steering Column
2. Neutral Position Springs
3. Housing
4. Check Valve
5. Spool
6. Sleeve
7. Cardan Shaft
8. Gear Rim
9. Gear Wheel
10. Spacer

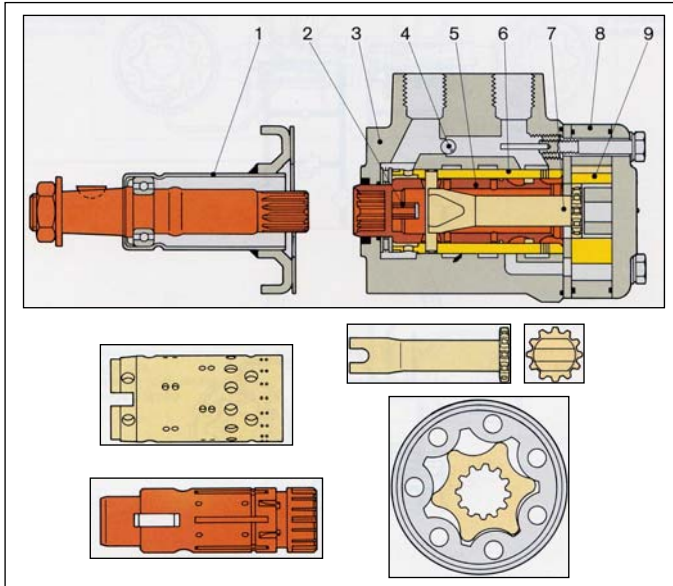

Simple Representation

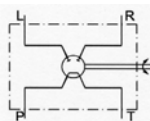

Complete Representation

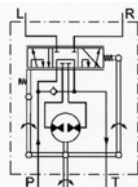

Hydrive Power Steering Helm Units Basic Dimensions

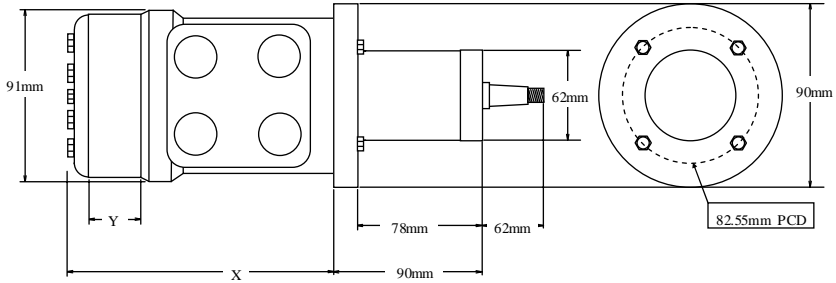

Helm Model	X in mm	Y in mm
PS50	126 mm	6.5 mm

Port Size: - 3/4" UNF - Oring boss

Bolt Size: - 3/8 x 16tpi - UNC
16 mm deep in the main body

Installing the column.

Hydrive steering columns and steering units must be assembled with nothing between them.

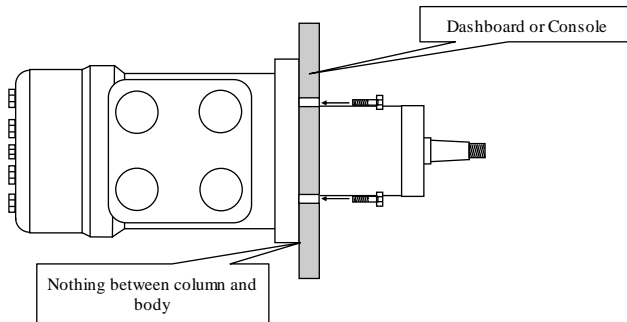

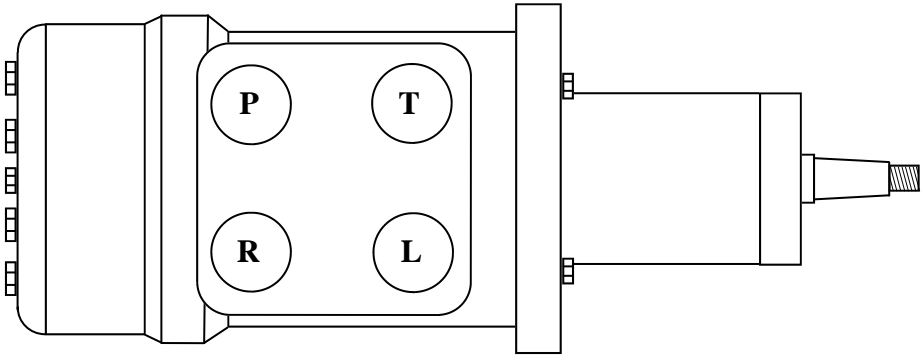

Port code on helm

- P** = **Pressure “In” (Output from pump set)**
- T** = **Tank “Flow out”. (Return to pump set, barbed fitting)**
- L** = **When steering wheel is turned / rotated “Left” (Anticlockwise) oil flows out of this port.**
- R** = **When steering wheel is turned / rotated “Right” (Clockwise) oil flows out of this port.**

STEERING COLUMN

1. Before attaching steering wheel, spray lubricant. Example: WD40, on to stainless steel shaft / plastic bushing to insure free rotation.
2. A chrome bezel is available as an accessory to cover the mounting studs, if required.

CYLINDERS

INSTALLATION ON OUTBOARD MOTORS

There are two basic types of cylinders designed for use with outboard motors. These install directly to the outboards as follows:-

TILT-TUBE CYLINDERS

These are designed to replace conventional cable steering systems, and attach directly to the tilt-tube of the outboard in much the same way as a conventional through-the-tube cable steering does.

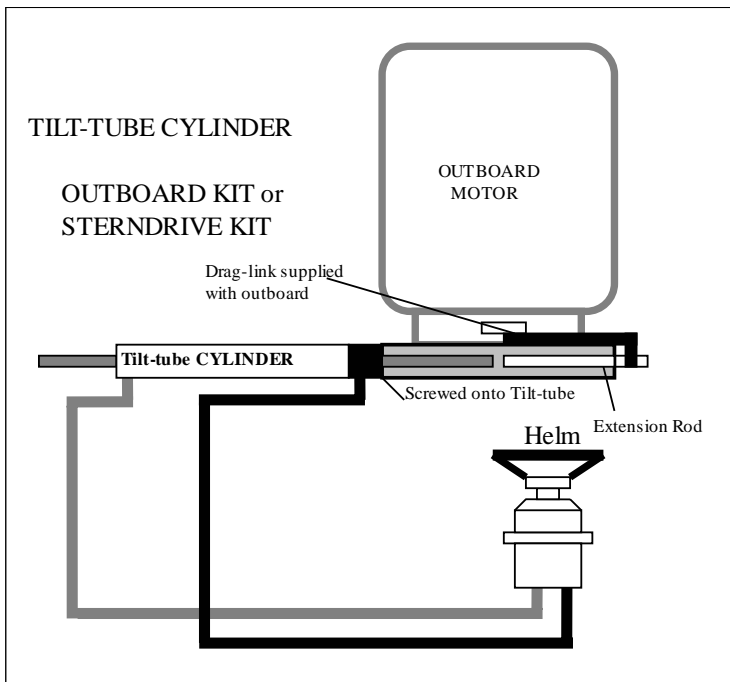

1. Simply fit the extension rod to the piston rod, and secure using a small quantity of loctite (1-2 drops only). Make sure the threads are clean and oil-free. This is to prevent the rod from unscrewing once installed. Spanner flats are provided on the piston rod for this purpose. **DO NOT GRIP THE PISTON ROD AT ANY TIME WITH ANY TOOLS ON THE WORKING SURFACE OF THE ROD.**
2. Inspect the TILT-TUBE of the outboard carefully, particularly if it is an old engine. These tubes are only made out of mild steel and often corrode. If any corrosion is present, the tube must be thoroughly cleaned and REAMED if possible before coating with good quality **WATER-PROOF** grease.
3. Slide the piston rod & extension rod through the tilt-tube of the outboard, and then screw the end-cap onto the tilt-tube thread. This is normally the Starboard side of the engine. ENSURE that the thread of the tilt-tube is not damaged in any way **BEFORE** attempting this action.
4. Once the cylinder is screwed onto the tilt-tube, position the cylinder so that the hose fittings are either facing towards the bow or on top. If the cylinder is particularly loose on the tilt-tube at this point, with some outboards this can be adjusted by loosening one side of the tilt-tube lock nut and tightening the opposite side to rotate the relative position of the tube. If this is not possible with your motor, then a small quantity of teflon thread paste or tape on the tilt-tube can be applied to compensate. Keep in mind that once the tubing is installed, there is no way of unscrewing the cylinder.
5. Install the tubing in accordance with the sections previously outlined for both nylon and copper tubing.

Attach the drag-link supplied with the outboard motor (this is a standard part supplied when the motor is new and is different for each brand). This connects to the tiller arm on one end and to the hole in the extension rod on the other.

BULLHORN TYPE CYLINDERS

The model 210BH cylinder (Front mounted) is one model from Hydrive "Admiral Series" range of cylinders and manual hydraulic helms. To install 210BH (Bull Horn) front mounted cylinders, **please refer to Admiral Series installation instructions, Page 12 and 13.**

A 304 Stainless steel 3/8 inch diameter tiller arm bolt (With 1/2 inch stainless steel shoulder bushing) has been supplied for recreational use under 250 H.P. outboard running under 60M.P.H.

We strongly recommend for outboards motor's exceeding 250H.P., high performance and / or high speeds over 60 M.P.H., a "high tensile steel" 3/8" diameter bolt (E.g. Grade 8, L-9 or equivalent) be installed on the tiller arm, together with the 1/2" O.D. stainless bushing supplied.

The bleeding "T" fitting must be installed into the cylinder using loctite on the pipe threads and with one arm pointing in the direction of the incoming hydraulic hose. Install fittings as per instructions supplied.

The HyDrive bullhorn type cylinders are designed to be installed on all brands of outboards equipped with tilt-tubes. They are simple to install by following these simple instructions.

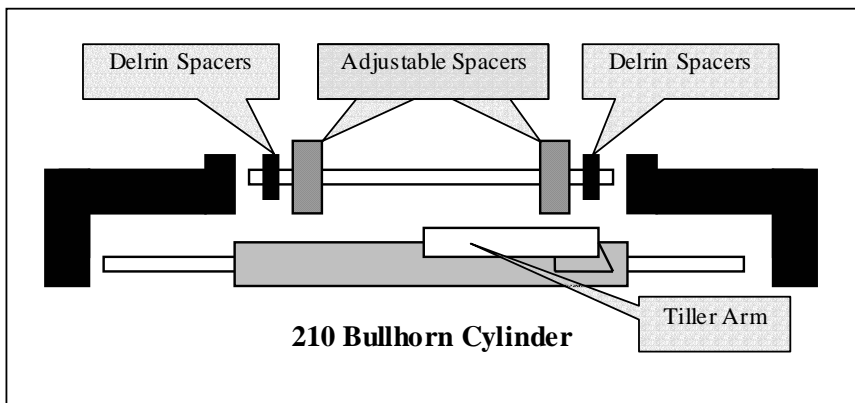

1. Lay out all the parts on a clean sheet of paper or bench and assemble the two horns onto the piston rod. Simply place the horn casting onto the piston rod as shown above and fit washers with the nyloc nuts. Tighten them firmly, using a spanner on each end of the piston rod and ensuring that the horns stay flat on the bench. This keeps them in the same plane. **Carefully read and follow** any instructions, or warnings, included with the cylinder.
 2. Remove the plastic dust plugs from the fittings. Using a ruler position the cylinder in the centre of the piston rod so that it is in the middle of it's stroke.
 3. Screw the adjusting spacer fully on to the tilt-tube of the outboard until it completely clears the thread at the end of the tube. On some outboards, the tilt-tube is threaded on both sides. Fit the second spacer if this is the case. Apply a liberal coating of waterproof grease inside.
 4. Position the motor dead-ahead so that the tiller arm of the motor is central. Now holding the cylinder firmly, position it either side of the tilt-tube. By aligning the hole of the tiller arms together, you can determine the best combination of the spacers to mount the cylinder close to central (You have been supplied with two large spacers and two small ones. Tilt-tube widths vary from one model to another so a combination of these sizes will allow you to fit the cylinder to any of them. Choose the best combination to best fill the gap).
 5. Insert the support rod through the port-side (left) horn casting and fit the plastic spacer(s) onto the rod between the horn and the tube. Push the rod through the spacer and then into the tilt-tube until it comes out the other side. Then fit one of the plastic spacers between the adjusting spacer and the horn. Push the rod completely through and then fit the washers and nyloc nuts to the rod. It is **ESSENTIAL** that there is a plastic spacer between each horn and the tilt-tube or adjusting spacer. The horns **MUST NOT** touch metal. They are fitted with internal electrical insulators, and contact with metal would render them useless. **TIGHTEN** the large nyloc nuts firmly, using two spanners. **DON'T OVER-TIGHTEN.**
-

6. With the support rod now tight, unscrew the adjusting spacer(s) to take up the slack between the spacers and the horn castings. **DO NOT USE TOOLS TO DO THIS.** Only use firm hand pressure as this is only to prevent minor side-movement of the cylinder. **The cylinder MUST be free** to rotate as the motor tilts. Once **FIRMLY** in position, tighten the grub-screws in the spacer(s) to prevent it loosening or tightening further as the motor tilts.
7. The pivot bolt can be inserted into the tiller of the outboard motor through the pivot bush in the steering unit's arm. The cylinder tiller should be attached under the tiller arm on most brands of outboards. In the event that the tiller interferes with other parts of the outboard, then it can be mounted on top of the tiller instead. The bolt should be fitted so that the stainless washer is in contact with the underside of the tiller bolt, hard against the bush. The bush should be tightened hard against the tiller as it will turn freely in the steering unit arm. Use the nyloc nut to ensure total lock onto the tiller. Now the cylinder and motor must be swung from lock-to-lock to ensure that there is no binding of the tiller arms.

IT IS VERY IMPORTANT TO ENSURE THAT THE TILLER ARMS DO NOT LINE UP, AND CREATE THE POSSIBILITY OF BINDING.

Should this appear to happen, you must adjust the cylinder to move the body of the cylinder closer to the right side of the boat, thus reducing the risk of the tillers being in line with each other. It does not matter if the motor appears to be off-centre when the cylinder is mid-stroke, as the two items swing different arcs anyway.

INSTALLATION ON STERNDRIVES

For those fitting tube-mount cylinders to sterndrives, the installation is very simple indeed. The stern-drive should have been supplied with a bracket which incorporates a threaded tube, normally used with a standard through-the-tube cable steering system. The tubemount cylinder assembles and attaches exactly as described in the previous section on Outboards, with the threaded mounting tube replacing the outboard's tilt-tube. The standard drag-link supplied with brand of sterndrive should be used.

INSTALLATION ON STANDARD RUDDERS

Hydrive standard cylinders with mounting brackets are designed for use with conventional rudders or jet units. The universal action of the mounting brackets, assist in minor misalignments in the installation. The geometry of the installation is still very critical to the ultimate performance of the unit so the following sections should be studied carefully. **“RUDDER STOPS”** should always be fitted to limit the rudder movement, and should ensure the stops engage before the cylinder reaches the end of the stroke. This is to prevent cylinder damage in the event of underwater collision.

SOME TYPICAL SINGLE CYLINDER INSTALLATIONS

The following is a short summary of some typical installations using single standard cylinder units. This is by no means the only way to install them, but is by far the most common. Should these methods present some difficulty for your boat, then please contact your agent, or the factory for their recommendations.

Because of obstructions in some boats, it may be necessary to position the slave cylinder fore and aft, rather than across the beam. In this case the tiller arm should be fixed at right angles to the rudder, and the slave cylinder should be mounted square to the tiller arm when the rudder is mid-ships.

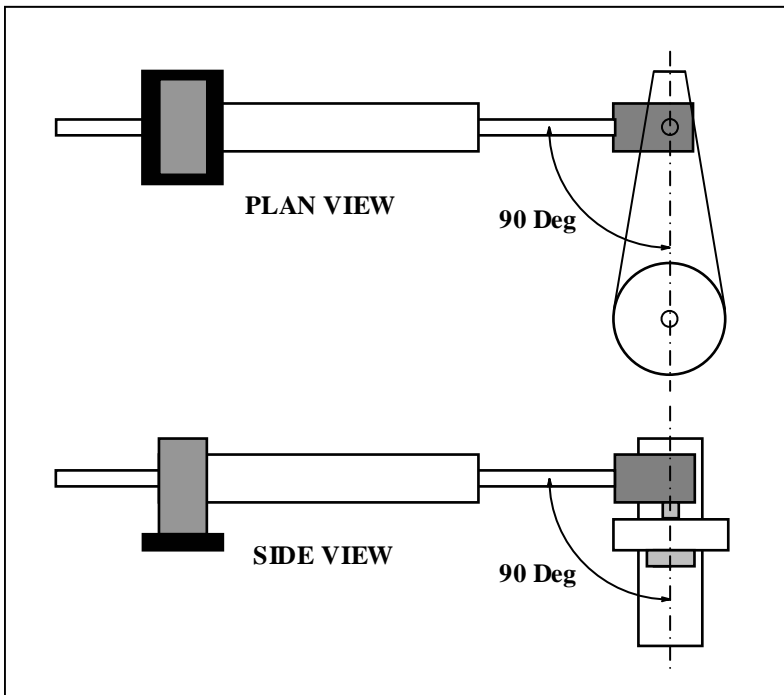

A typical single rudder installation is shown on previous page. The rudder should be in-line with the tiller arm, and the slave cylinder should be mounted squarely to the tiller arm. Please also note that the cylinder should be both square and parallel to the tiller arm.

For **twin rudders** the cylinder can be mounted on the outside of the tillers, or can push a pivot on the tie-rod itself. Please ensure that the cylinder is mounted so that it does not foul on the tie-bar as it turns hard-over.

HOSES

Three high-pressure braided flexible hydraulic hoses are supplied.

A fourth hose, "Return to pump set" (Between helm and pump set) is attached via a barbed fitting and dual stainless steel clamps.

BLEEDING

This full power steering system may be “Bled” as a recirculating open loop at tank system. Consequently, if the oil can fill and bypass at the cylinder, the continuous flow in one direction will allow returning aerated oil to self purge in the tank.

Directions as follows.

- 1.** Fill pump with oil. Switch pump set to “On” and after one minute oil level will drop. Keep adding oil to cover above internal flat plate. (This purges the Pump set, Hoses & Helm).
 - 2.** Single cylinder: (Front mounted or side mounted) Hydrive cylinders are supplied with non-drip bleed nipples. Loosen (One and a half turns) both bleed nipple retaining nuts, and pull both nipples “Out”. Attach ¼’ I.D. clear plastic tubing (Supplied) to both nipples.
 - 3.** Keeping the oil level above the internal flat plate, slowly rotate steering wheel clockwise (Starboard turn) so that a continuous flow travels down to the cylinder.... It will exit the first bleed nipple via the clear plastic hose and flow back into the second bleed nipple.... This flow will continue back up to the steering helm and flow back into the pump set, where any air vents to the atmosphere in the tank.
 - 4.** 25 to 30 rotations of the wheel may be required until the monitored flow across the clear plastic tube has no more air bubbles. Repeat the last 2 steps rotating wheel anticlockwise. (Port)
 - 5.** Rotate wheel port and starboard to check responsiveness of the cylinder.
 - 6.** With cylinder in “Dead ahead” position rock steering wheel to port and starboard to check degree of cylinder travel along cylinder rod. Up to ¼’ travel would be acceptable, as this is the expansion in the hydraulic hoses themselves.
-

Hose Connections 210BH & 212BH

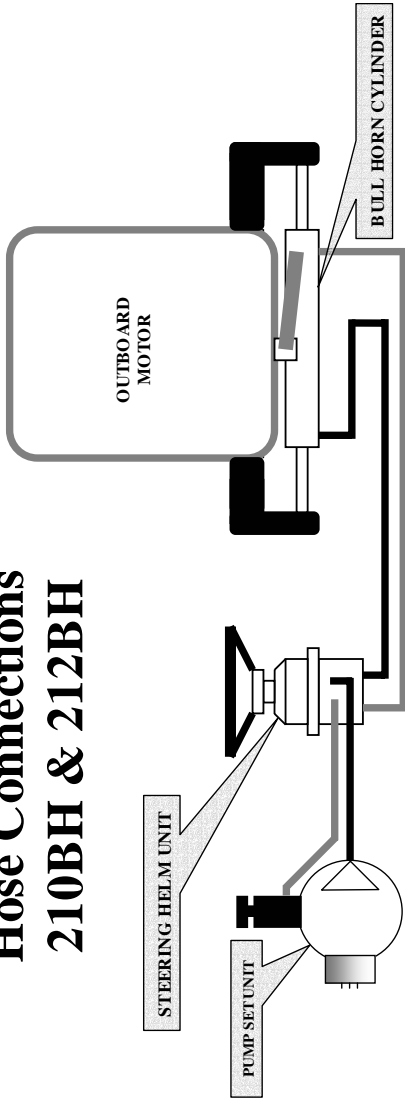

Hydraulic Circuit

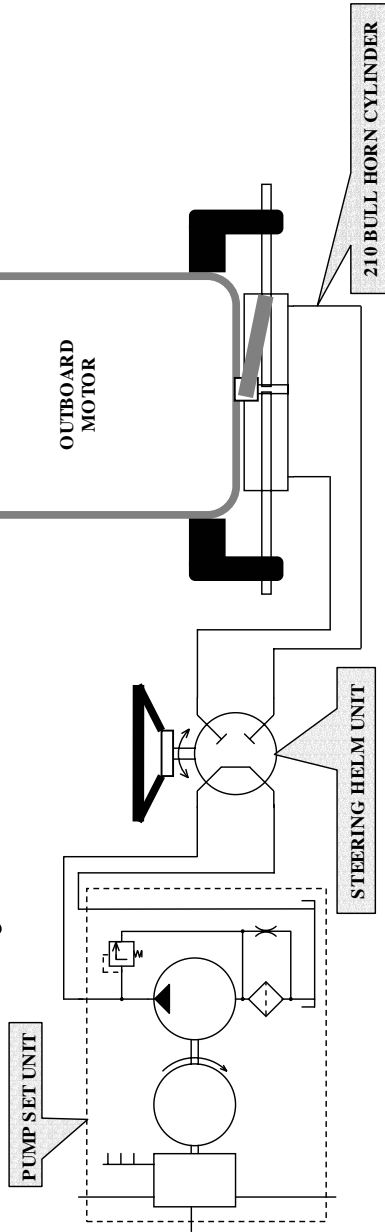

Hose Connections - All Inboard Models

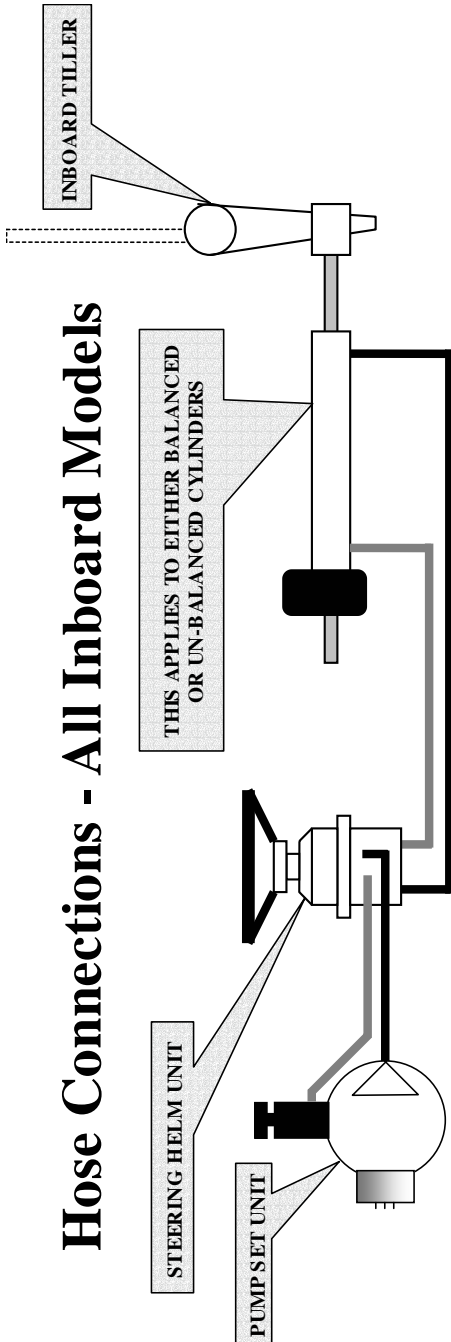

Hydraulic Circuit

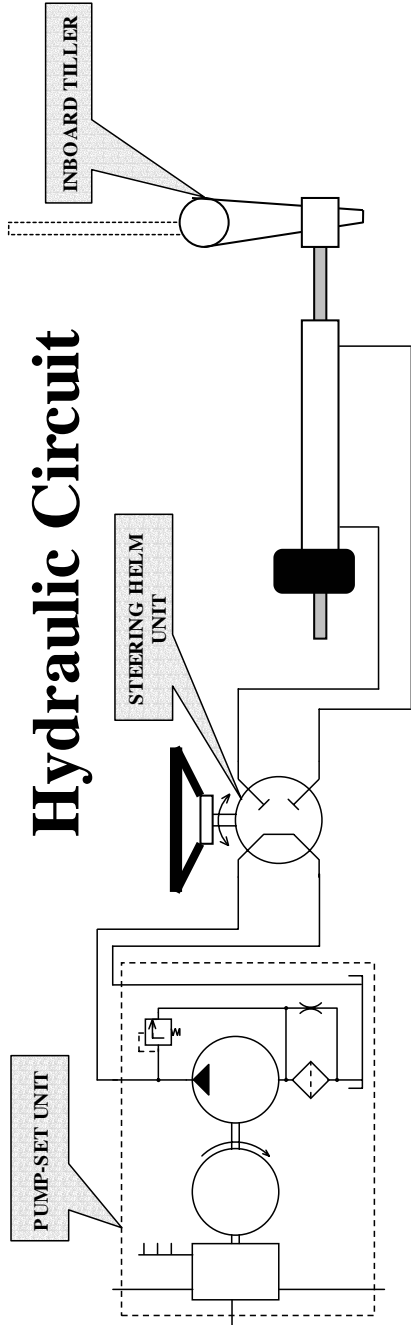

Hose connections for Single Helm with Auto Pilot

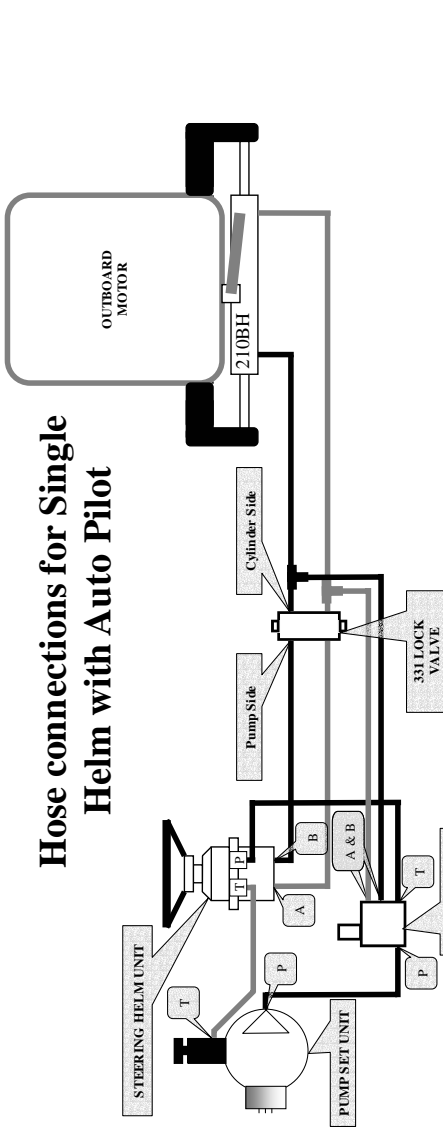

Hydraulics Circuit for Single Helm with Auto Pilot

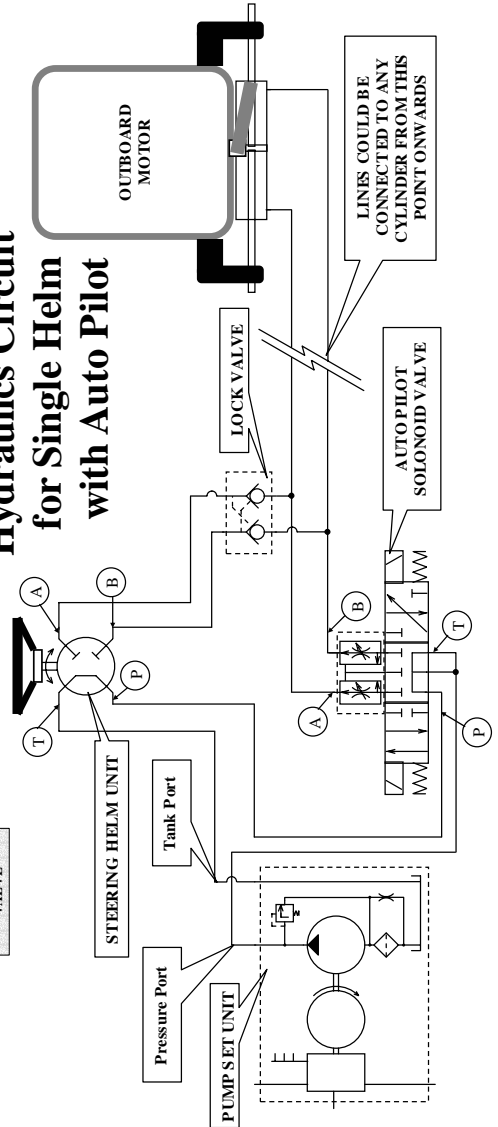

Fluid-link system for Catamaran Using 210BH & 212BH cylinders

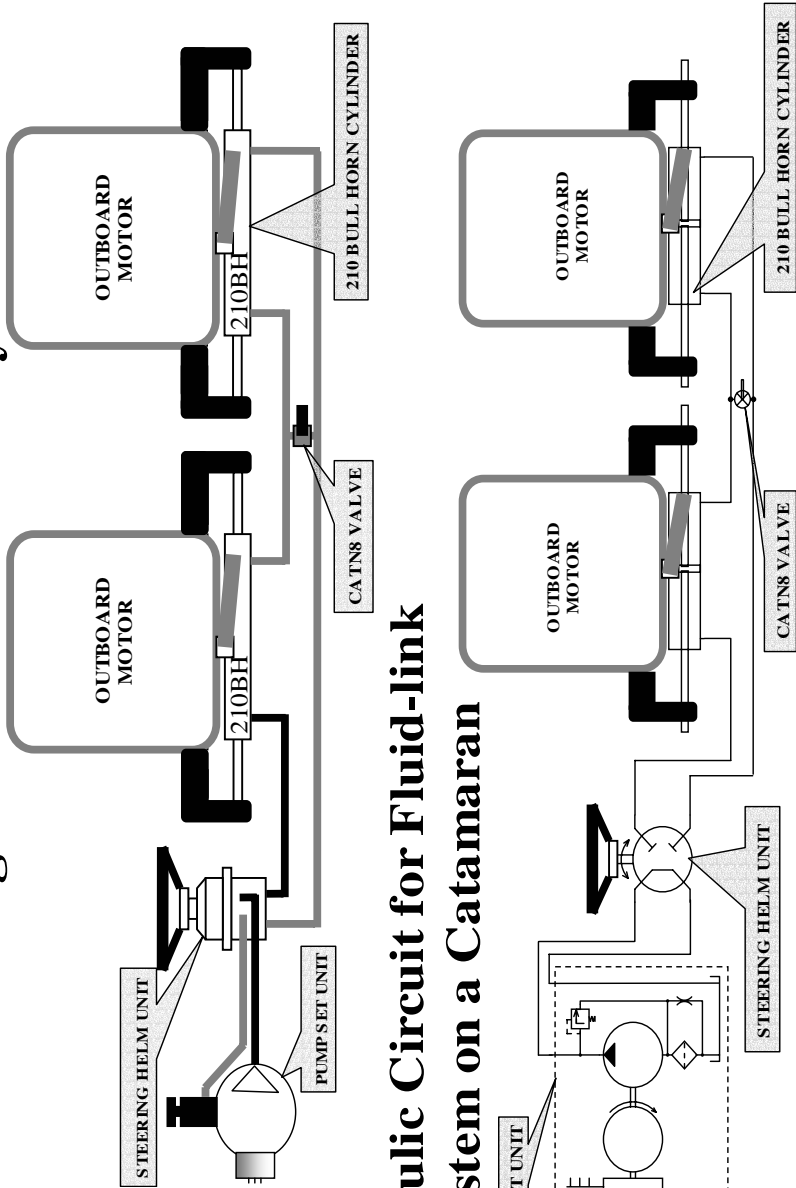

Hydraulic Circuit for Fluid-link system on a Catamaran

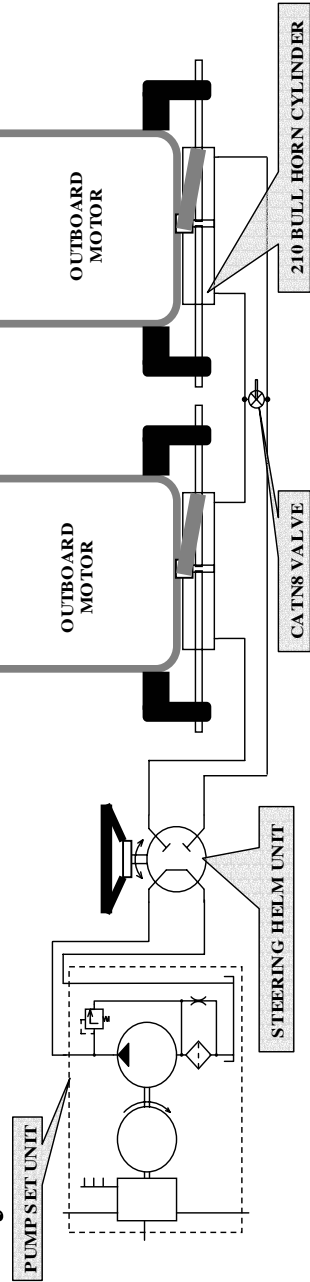

Hose Connections for Dual Helm

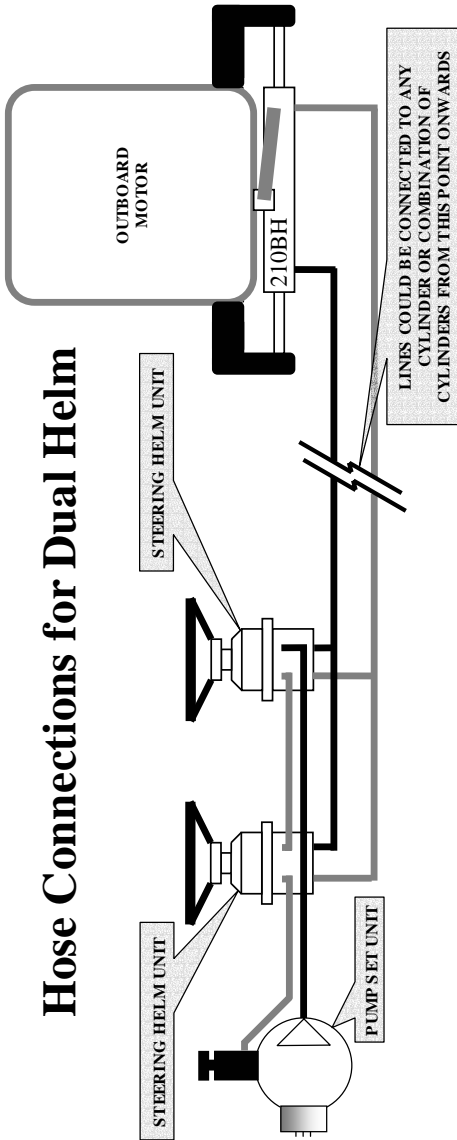

Hydraulic Circuit for Dual Helm

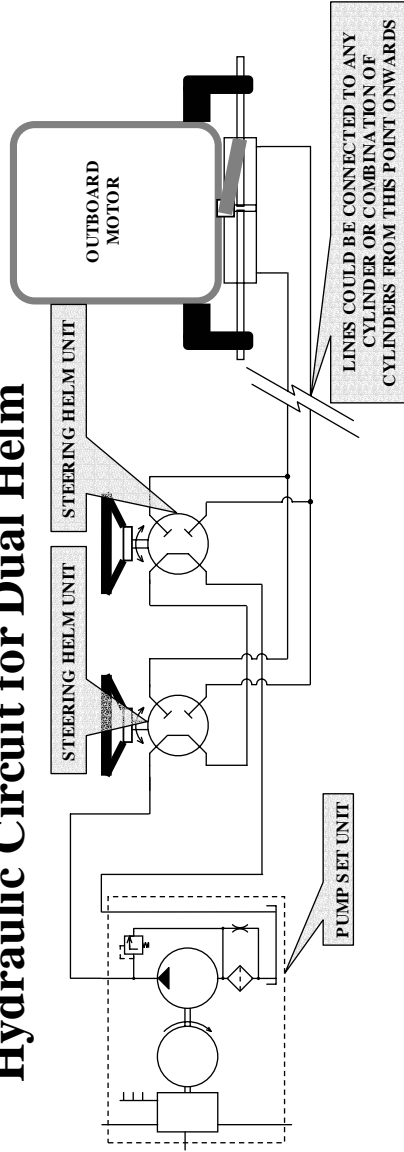

Hose Connections for Dual Helm

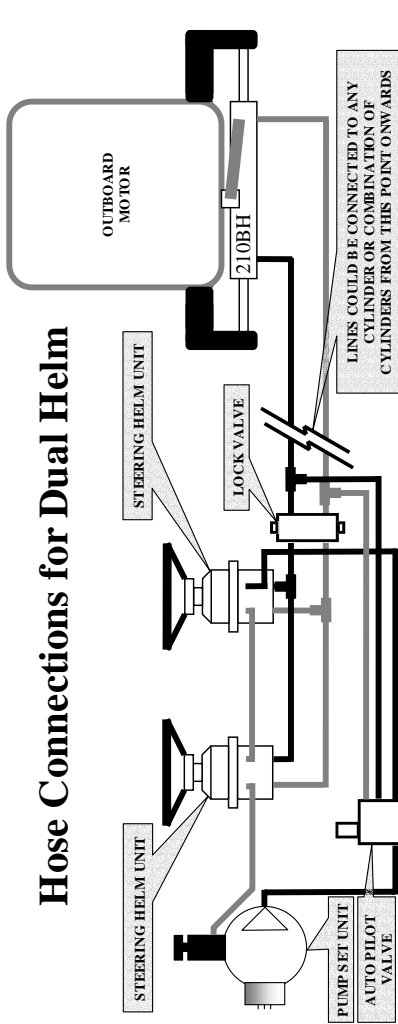

Hydraulics Circuit for Dual Helm with Auto Pilot

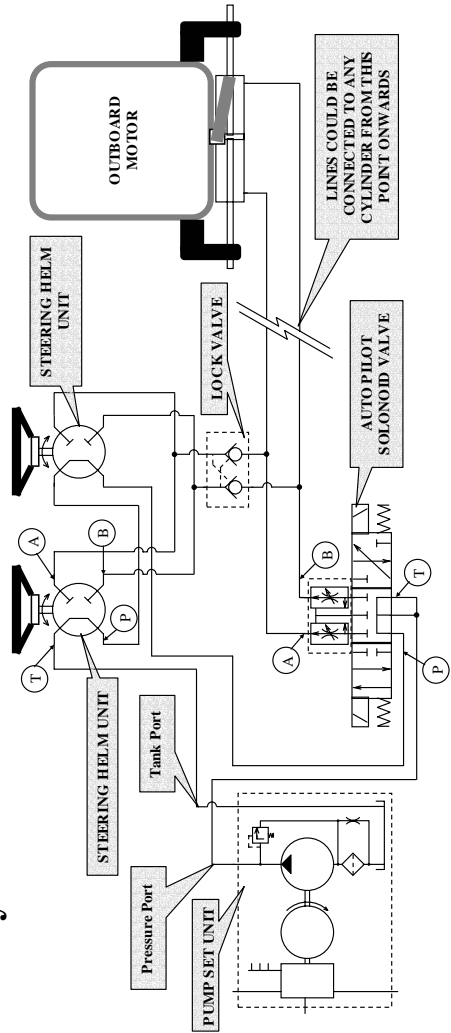

SERVICE INFORMATION

Due to the design of the equipment and in most cases is limited to seal replacements only. Full seal kits are available for each system and can be readily obtained from any of our dealers. Each seal kit comes with a simple instruction sheet on how to replace the seals in your unit. Before obtaining seals you must know the model number of your units, so check the labels before ordering the parts.

Some simple terms that will make ordering parts much simpler - The helm units where the wheels fit are referred to as "HELMS". The slave cylinders attached to the motors or tillers are referred to as "CYLINDERS" or "RAMS". Try not to get the two confused or you may end up ordering the wrong parts.

UNDER NO CIRCUMSTANCES attempt to dismantle a helm unit without obtaining service instructions from your dealer. *If under warranty, your warranty becomes void if dismantled by an un-authorized person.* **If poorly handled, you can SERIOUSLY damage your unit.**

MAINTENANCE

Maintenance on Hydrive steering is minimal, but because of this is it is often forgotten altogether. This results in problems at a later date due to wear on components that normally last a lifetime. Specifically mounting brackets (on 210 standard only) do require to be greased at intervals of around 3 months during seasons of heavy use. If the boat is going to be left idle for long periods, then grease thoroughly the grease nipple and ball-joints on the slave cylinder and also cover the stainless shaft to prevent salt build-up etc that can cut the seals when first used. Any other exposed metal should be greased.

ONLY USE WATERPROOF GREASE, as other automotive type greases can absorb moisture and may actually encourage corrosion.

On units installed on outboard motors, as part of your **REGULAR** service on the outboard, all components of the motor and steering should be hosed down with fresh water after each trip. A spray of WD40, RP7 or similar **DE-WATERING LUBRICANT** on all motor parts and steering parts will ensure long life of both.

REGULARLY check:

- 1) OIL LEVELS**
 - 2) SECURITY OF ALL BOLTS, NUTS, CLEVIS PINS & STUDS**
 - 3) SECURITY OF ALL HOSE FITTINGS**
 - 4) GREASE (Where applicable)**
 - 5) SPRAY WITH RP7 OR SIMILAR PRODUCT**
 - 6) DO NOT MIX OILS IN THE UNIT.**
-

Warranty Statement

HyDrive Admiral Series steering units are warranted by the manufacturer against defect in workmanship and materials for **24 months** from date of sale. *For Sportkits or where systems are used on COMMERCIAL craft, for hire or commercial purposes warranty is limited to 12 months.*

FACTORY WARRANTY

Units suspected of warranty problems should be returned **to the factory**, freight paid together with your name, address and description of the problem. No inbound freight charges will be accepted.

Warranty is limited only to repair or replacement of any component found to be faulty and such repair or replacement is solely at the discretion of the manufacturer. It does not extend to normal wear and tear; collision damage; damage due to entry of foreign material; or corrosion due to electrolysis.

Should the repairs be affected by a ***DULY AUTHORISED SERVICEMAN***, then warranty is limited only to the replacement of parts and the labour required to effectively install those parts. Travelling times are **NOT** covered by warranty but must be compensated by the owner. Hydrive Engineering Pty Ltd will in no way be liable for more than the cost of the original product.

WARNING

Care of the **ENVIRONMENT** is the responsibility of all individuals and not that of someone else. If you love fishing or boating, then please take good care of the sea and its environment. **HYDRAULIC OIL** is ***NOT ENVIRONMENTALLY FRIENDLY*** and care should be exercised to prevent oil used during the bleeding process from running overboard, or into the bilge where it will be pumped into the sea.

It only takes a little time and patience to protect the sea from further pollution. Please dispose of all waste oil, rags, plastic bags and other materials, thoughtfully and in a responsible manner.

**WE WISH YOU HAPPY
BOATING!**

